



APPLICATIONS

VTNEUROPE.COM

HARDOX
WEAR PLATE

HARDOX
IN MY BODY



SERIE CK COMBI KIT:

- 6 modelli per escavatori da 7 a 50 t
- Rotazione a 360°
- Gruppo di rotazione compatto
- Cilindro interamente protetto
- Valvola di velocizzazione (da CK14)
- 5 kit chele intercambiabili*
- Taglienti intercambiabili
- Puntali intercambiabili (da CK11)

SERIE CK COMBI KIT:

- 6 modèles pour pelles de 7 à 50 t
- Rotation 360°
- Groupe de rotation compact
- Vérin entièrement protégé
- Speed Valve (du CK14)
- 5 jeux de mâchoires interchangeables*
- Couteaux interchangeables
- Plaques de dents interchangeables (du CK11)

CK SERIES COMBI KIT:

- 6 models for excavators with operating weight from 7 t to 50 t
- Compact-designed 360° rotation
- Fully-protected cylinder
- Speed Valve (from CK14)
- 5 interchangeable kits for different tasks*
- Interchangeable blades
- Interchangeable tips (from CK11)

SERIE CK COMBI KIT:

- 6 Modelos para excavadoras de 7 a 50 t
- Rotación a 360°
- Grupo de rotación compacto
- Cilindro totalmente protegido
- Válvula de velocidad (de CK14)
- 5 tipologías de mandíbulas intercambiables*
- Cuchillas intercambiables
- Puntales intercambiables (de CK11)

CK SERIE COMBI KIT:

- 6 Modelle für Bagger mit Einsatzgewicht von 7 bis 50 Ton
- Kompakter 360° Rotationseinheit
- Komplette Zylinderschutz
- Eilgangventil (von CK14)
- 5 Wechselgebisse verfügbar für verschiedene Arbeitsvorgänge*
- Wechselbare Spitzen
- Wechselbare Messer (von CK11)

СЕРИЯ CK Новые мультифункциональные гидроротирующие

- 6 моделей, от 7-ми до 50-ти тонных экскаваторов
- 360° гидравлическая система ротации
- Компактный роторный блок
- Полностью защищенный цилиндр
- Скоростной клапан (от CK14)
- 5 комплектов челюстей*
- Сменные ножи
- Сменные коронки (от CK11)

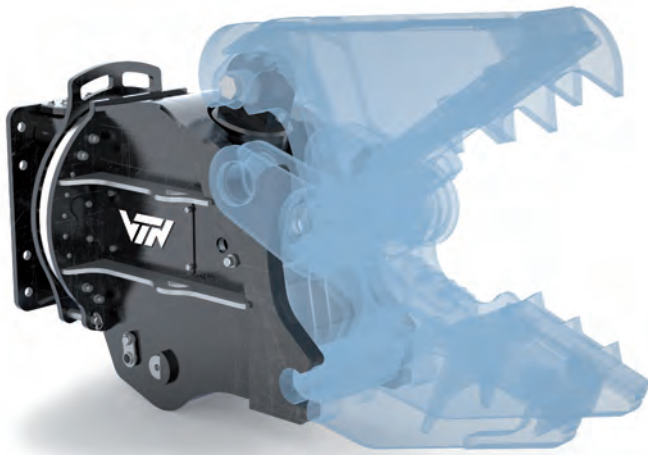

Model		CK07	CK11	CK14	CK21	CK28	CK36
	°	360	360	360	360	360	360
	l/min	5/8	20 / 30	20 / 30	20 / 30	20 / 30	40 / 50
	bar	120	120	120	120	120	120
	l/min	70/90	90/140	110 / 160	170 / 210	200 / 250	300 / 400
	bar	230/350	280/350	350	350	350	350
	Kg	485	655	905	1224	1555	2090
	t min/max	7/13	10/16	13 / 21	18 / 27	26 / 35	35 / 50

*Altri modelli di Chele disponibili su richiesta - *Other models of Jaws available on request



DEMOLIZIONE · DEMOLITION





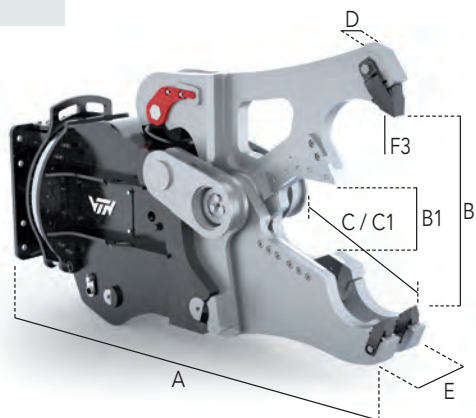

CK SERIES

Combi Kit







R - Combi

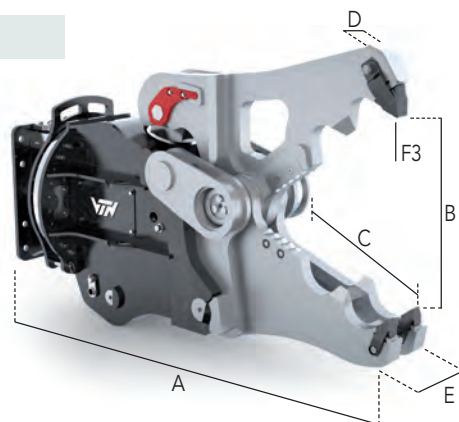

Model		CK07	CK11	CK14	CK21	CK28	CK36
Jaws type		R	R	R	R	R	R
A	mm	1595	1785	1994	2070	2460	2555
B / B1	mm	530 / 265	610 / 320	717 / 338	780 / 358	861 / 440	957 / 470
C / C1	mm	480 / 280	580 / 320	700 / 340	760 / 340	810 / 430	910 / 430
D	mm	60	60	70	70	90	110
E	mm	230	230	260	260	340	370
	mm	280	320	340	340	430	430
F3	t	45	53	62	75	95	115
 Total	Kg	767	1160	1570	2113	2772	3770
 Jaws	Kg	282	505	665	889	1217	1700
	mm	25	30	30	35	40	50
	mm	100	120	160	240	270	330
	mm	/	/	120	180	200	240

D - Pinza - Crusher



Model		CK07	CK11	CK14	CK21	CK28	CK36
Jaws type		D	D	D	D	D	D
A	mm	1595	1785	1994	2074	2356	2555
B	mm	520	610	717	780	865	957
C	mm	500	580	700	760	810	910
D	mm	50	60	70	70	80	90
E	mm	190	240	240	240	270	300
	mm	150	150	200	200	200	200
F3	t	45	53	65	80	105	120
 Total	Kg	710	1130	1504	2066	2650	3615
 Jaws	Kg	225	475	599	842	1095	1525
	mm	20	25	30	35	40	50

P - Frantumatore - Pulverizer

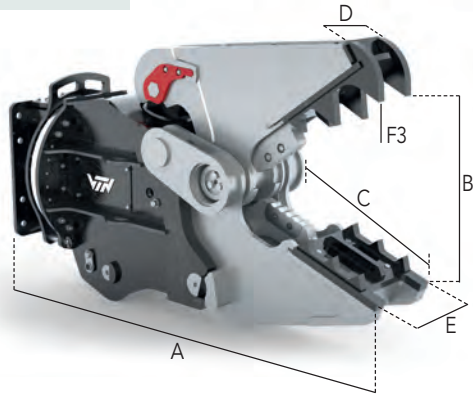

Model		CK07	CK11	CK14	CK21	CK28	CK36
Jaws type		P	P	P	P	P	P
A	mm	1620	1780	1995	2088	2378	2585
B	mm	535	630	720	780	890	980
C	mm	525	630	730	780	880	930
D	mm	170	185	260	260	300	340
E	mm	290	320	380	380	420	470
F3	mm	85	150	150	200	200	200
F3	t	45	53	62	75	95	115
Total	Kg	766	1140	1550	2111	2745	3760
Jaws	Kg	281	485	645	887	1190	1670
●	mm	20	25	30	35	40	50

S - Cesoia - Scrap Shear

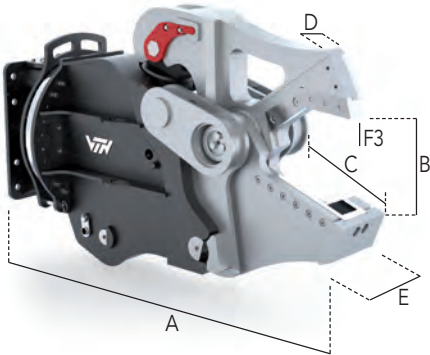

Model		CK07	CK11	CK14	CK21	CK28	CK36
Jaws type		S	S	S	S	S	S
A	mm	1475	1610	1826	1853	2134	2350
B	mm	265	335	392	392	490	555
C	mm	335	340	493	493	600	650
D	mm	90	90	105	105	120	120
E	mm	260	260	280	300	380	415
F3	t	65	70	85	110	130	160
Total	Kg	730	1085	1502	2027	2640	3610
Jaws	Kg	245	430	597	803	1085	1520
●	mm	30	35	40	50	60	70
—	mm	6	8	10	12	15	20
I	mm	120	140	180	270	330	360
I	mm	-	-	140	200	240	260

CH - Swiss

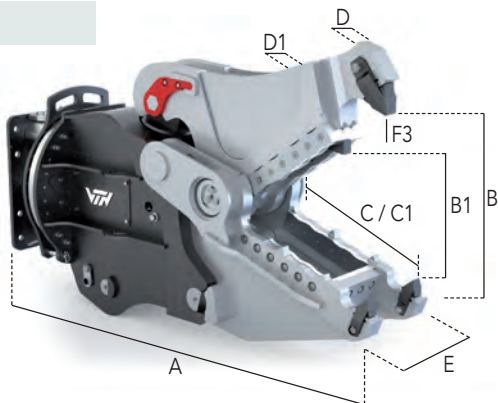

Model		CK07	CK11	CK14	CK21	CK28	CK36
Jaws type		CH	CH	CH	CH	CH	CH
A	mm	1575	1730	1954	2063	2365	2590
B / B1	mm	350	425	620 / 410	755 / 550	843 / 690	935 / 775
C / C1	mm	430	510	630 / 410	677 / 470	795 / 593	870 / 610
D / D1	mm	195	205	70 / 222	70 / 262	80 / 292	90 / 320
E	mm	300	330	350	390	440	490
F3	t	60	65	65	75	95	115
Total	Kg	772	1135	1601	2180	2862	3910
Jaws	Kg	287	495	696	956	1307	1820
●	mm	20	25	30	35	40	50